

## **ANNEXES**

- **Croquis illustrant certaines données réglementaires**
- **Planches illustratives et référence aux lois et règlements fédéraux et cantonaux**

## ZONE DU VILLAGE

### **Art. 13** Implantation des constructions

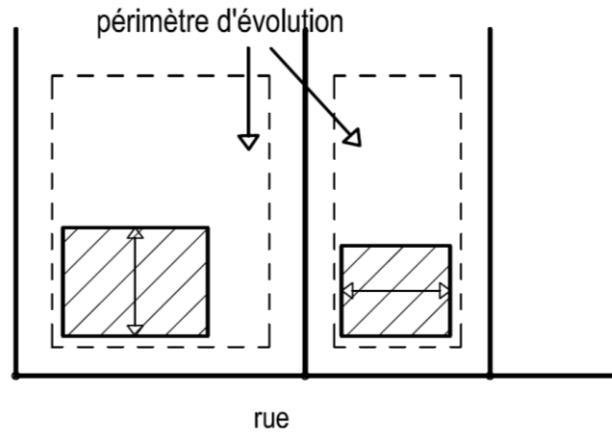

### **Art. 14** Ordre des constructions

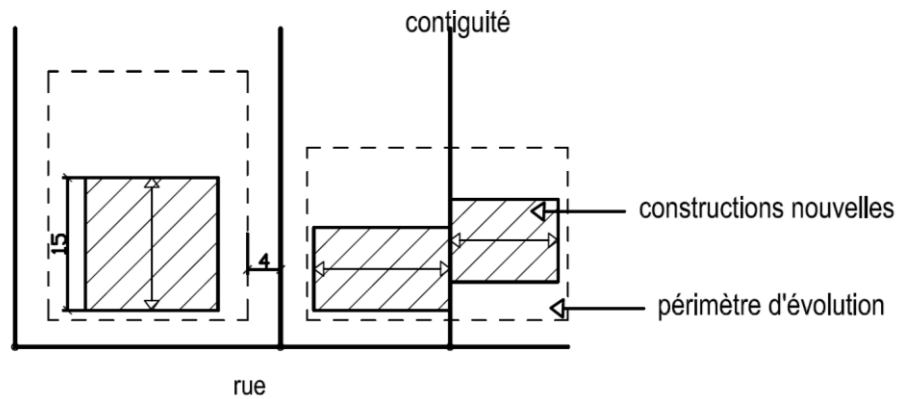

### **Art. 15** Gabarit

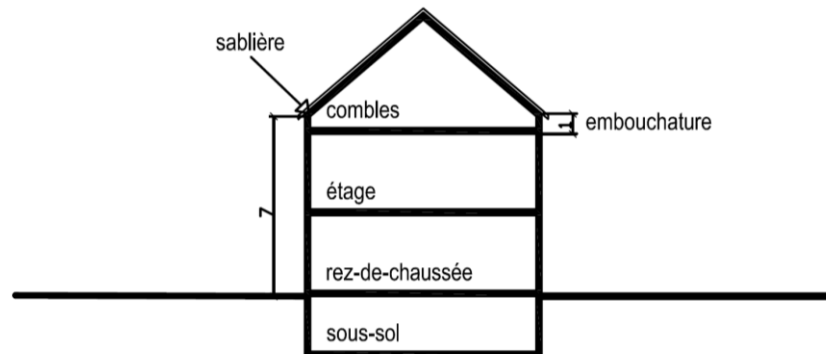

### **Art. 18 et 19** Surfaces de prolongements extérieurs

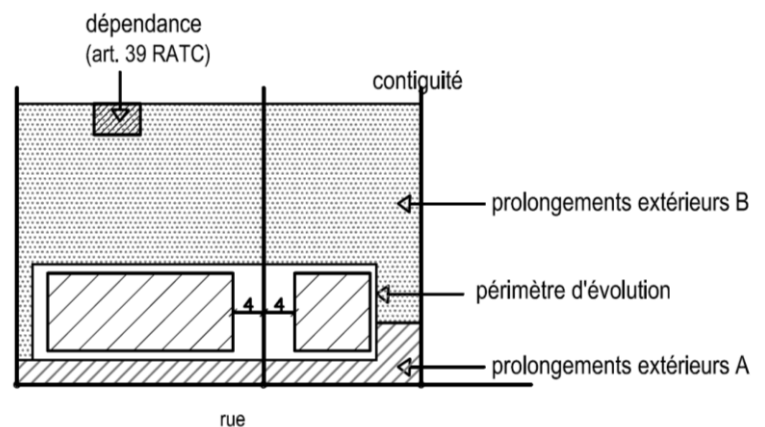

# ZONE DE VILLAS

## Art. 21

3 logements contigus ou superposés

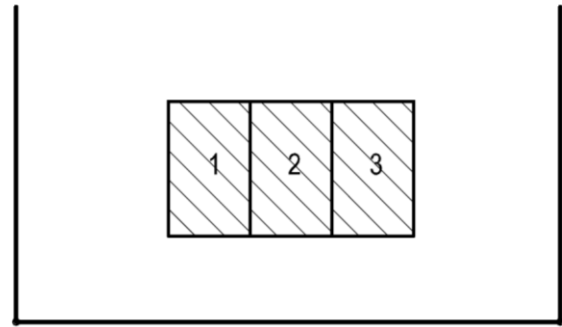
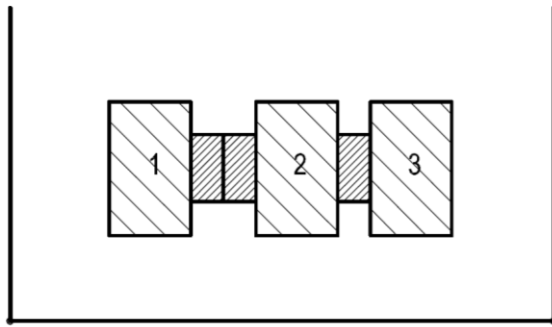
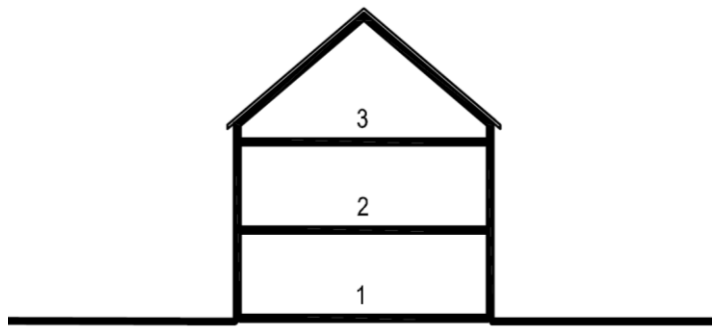

## Art. 23

Distances entre façades et limites de propriété

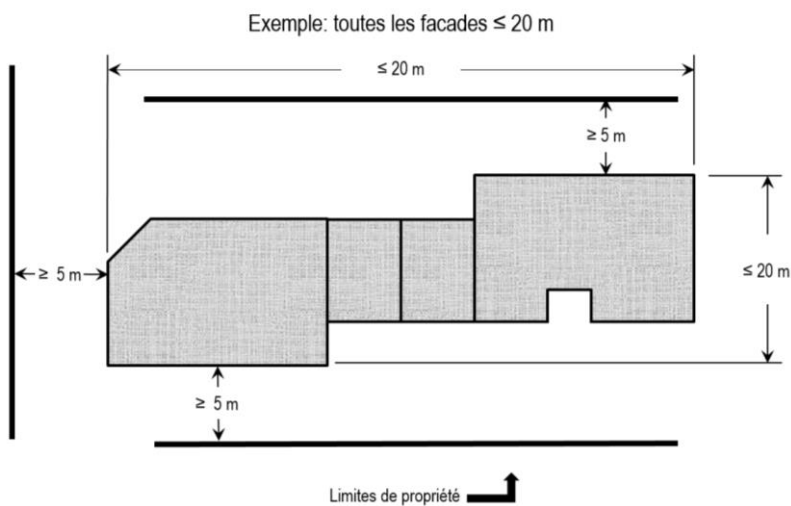
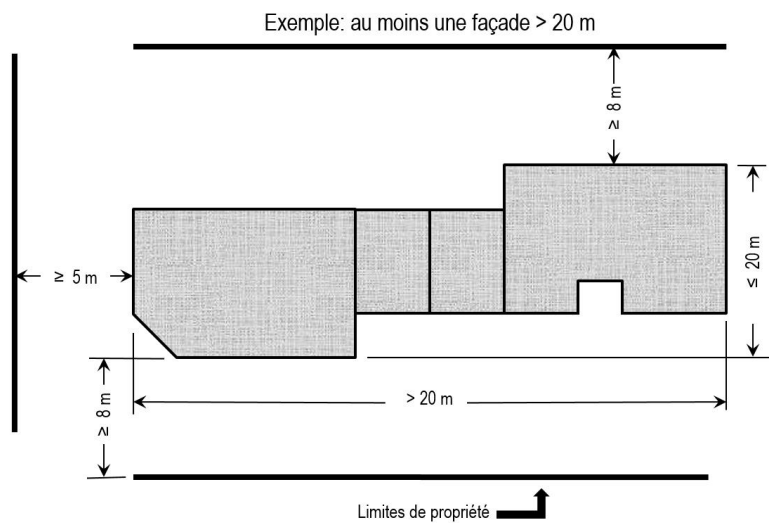

**Art. 64**  
Limites des constructions

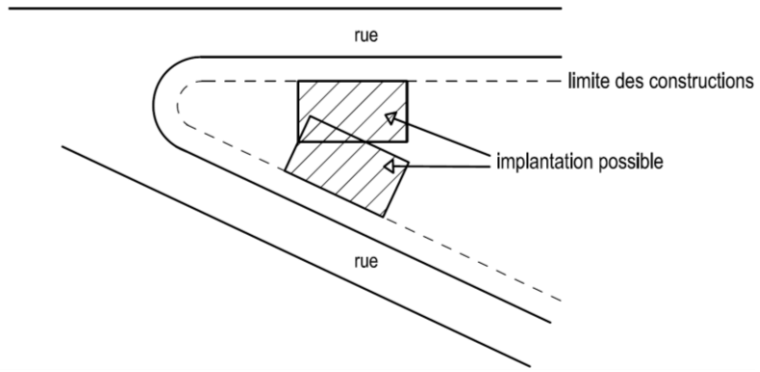

**Art. 67**  
Calcul du coefficient  
d'utilisation du sol (CUS)

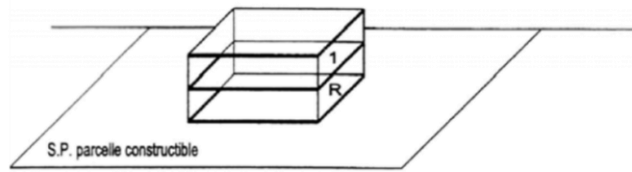

$$U = \frac{\text{Indice d'utilisation} \quad S.R + S.1}{S.P.}$$

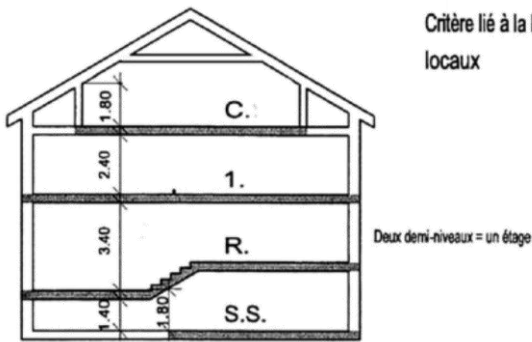

Critère lié à la hauteur des locaux

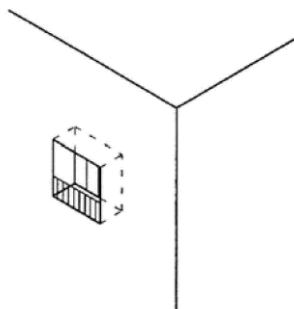
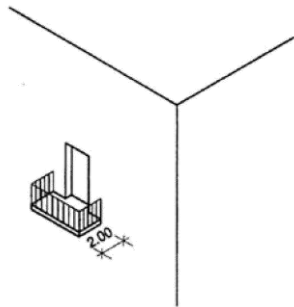

Balcons et loggias ne sont pas pris en compte dans la surface brute de plancher utile.

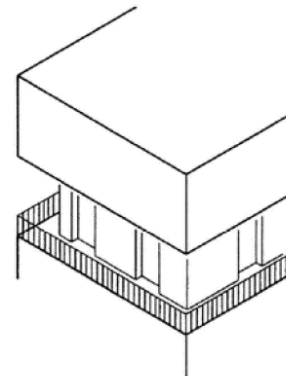

Coursives et oriels sont pris en compte dans la surface brute de plancher utile.

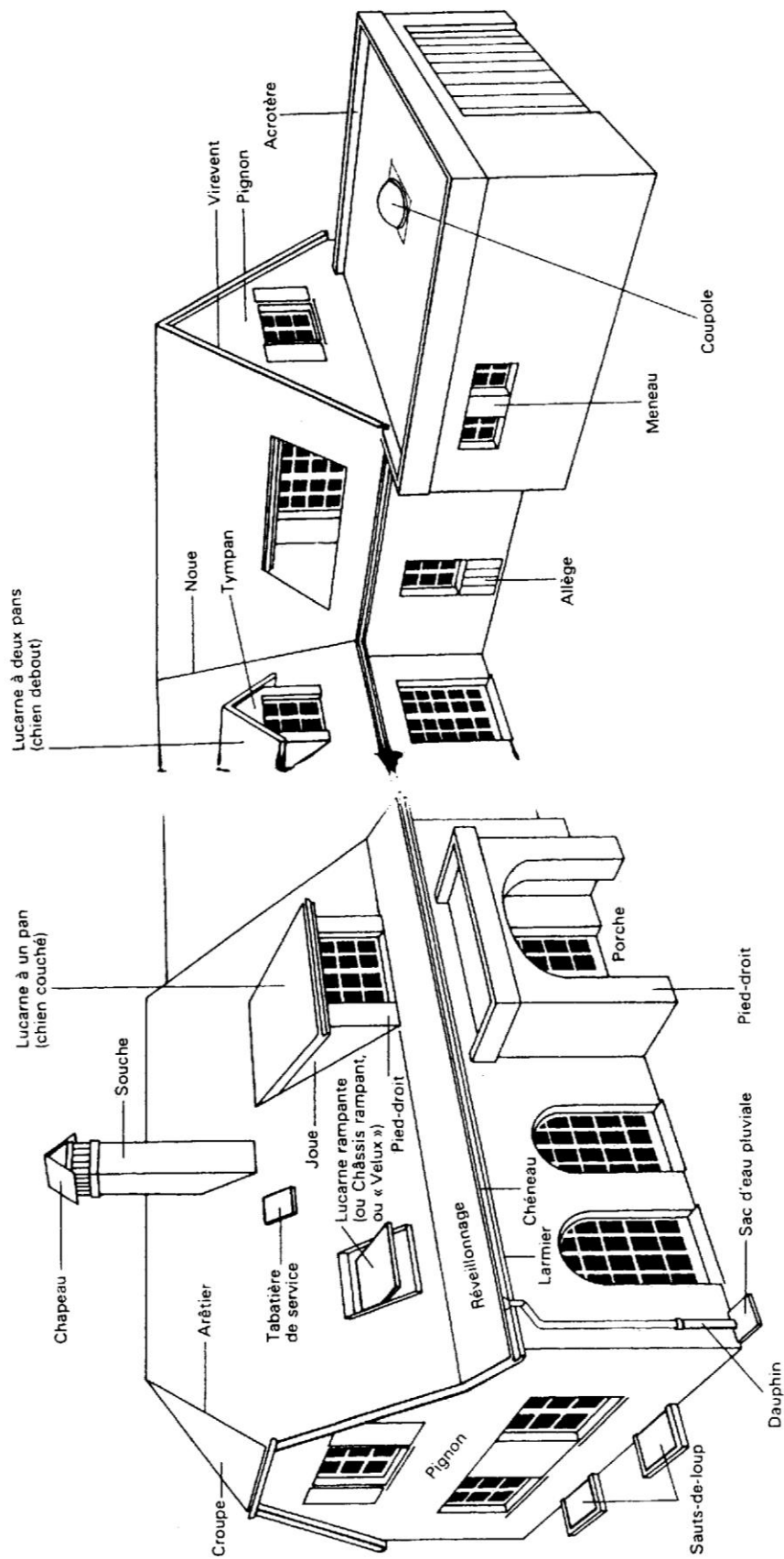



Planche 4



Planche 5

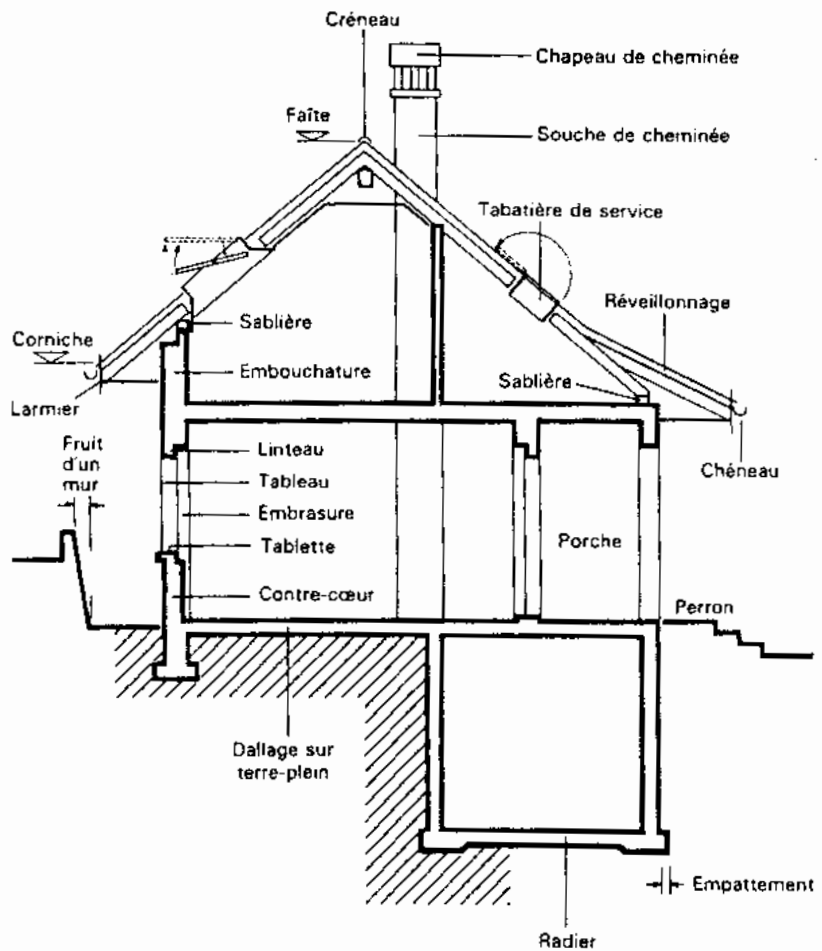
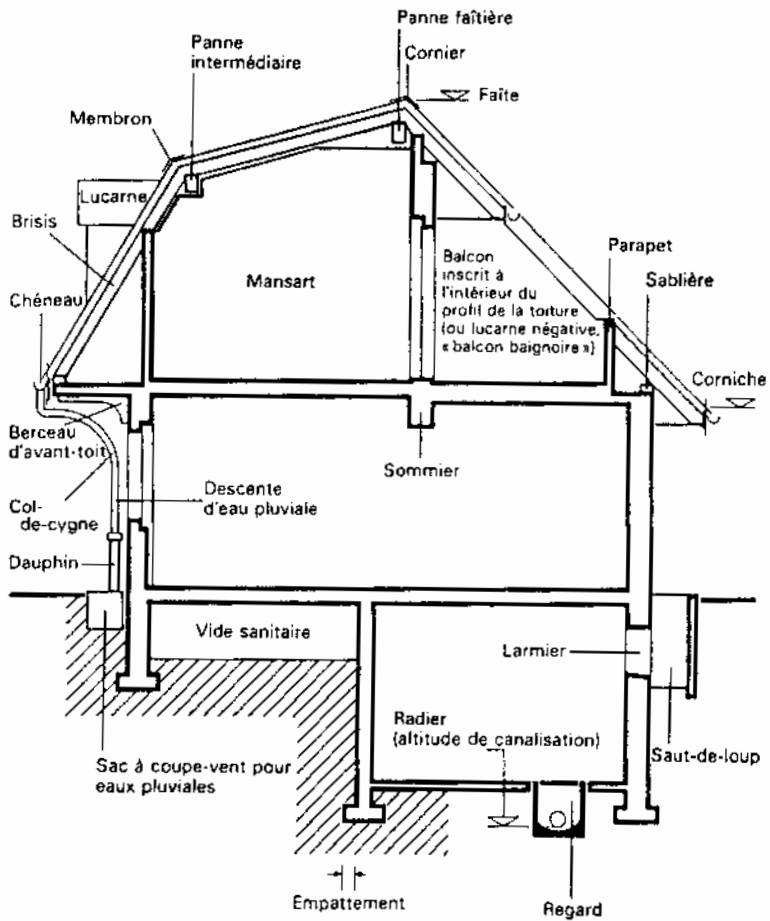
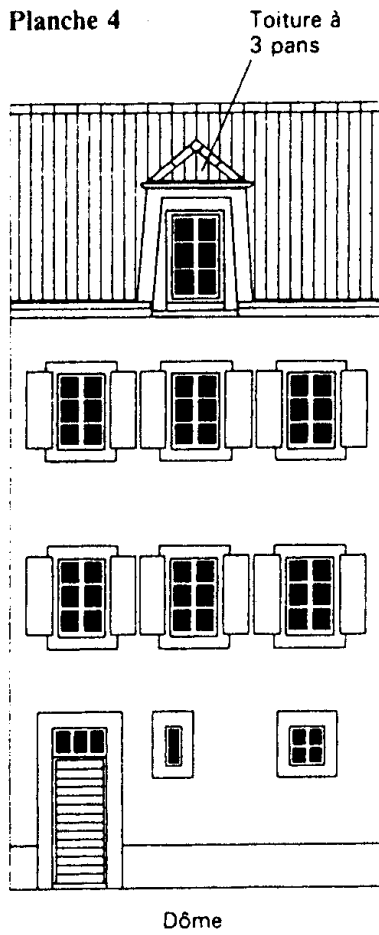
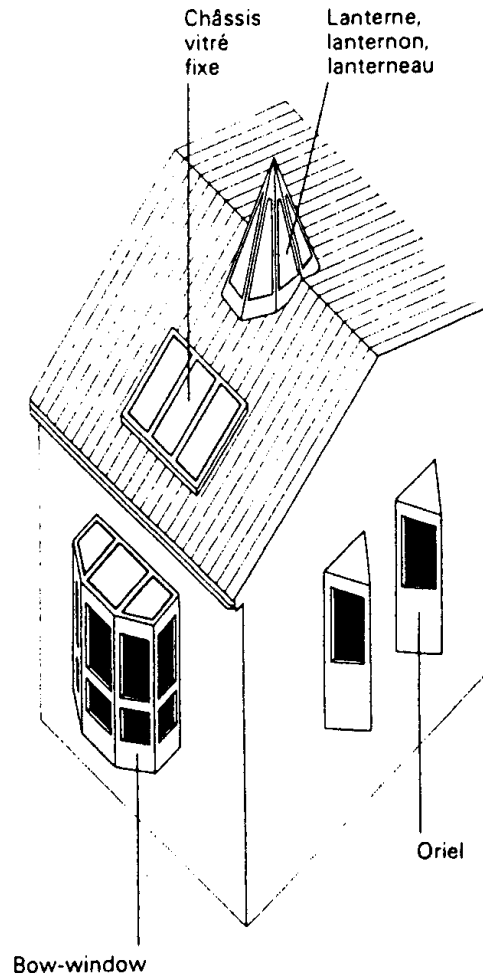

**Lois et règlements fédéraux et cantonaux :**

**A consulter directement auprès des instances concernées**